

CARBON STEEL GATE VALVE FLANGED CLASS 300 PN50



Size : DN 50 to DN 400 (NPS 2" to 16")
Ends : Flanges R.F. CLASS 300 (PN50)
Min Temperature : - 29°C
Max Temperature : + 425°C
Max Pressure : 50 Bars
Specifications : Rising, non-rotating stem
Bolted bonnet and gland pack
Full bore

Materials : Carbon steel

CARBON STEEL GATE VALVE FLANGED CLASS 300 PN50

SPECIFICATIONS :

- Full bore
- Rising, non-rotating stem
- Fixed non rising handwheel
- Flexible one piece wedge
- Flanges R.F. Class 300 (PN50)
- Carbon steel body
- Bolted bonnet and gland pack
- ½ stellite (Trim 8 , seat with stellite)
- Grey painting RAL 7001 color, 60 µm thickness

USE :

- Water distribution, gas oil, steam, petrochemical, petroleum industry, gas
- Min and max Temperature Ts : - 29°C to + 425°C
- Max Pressure Ps : 50 bars
- **Do not use with scraper**
- **Tighten the gland packing in service**

FLOW COEFFICIENT Kvs :

DN (mm)	50	80	100	150	200	250	300	350	400
NPS (")	2"	3"	4"	6"	8"	10"	12"	14"	16"
Kvs	60	94	162.8	366.3	651.1	1017.4	1456	1838	2438

PRESSURE / TEMPERATURE RELATION :

(According to AMSE B16-34 for A216 WCB)

Pressure (Bar)	51.1	51.1	46.2	45.1	43.8	41.3	37.9	36.9	36.9	34.8	28.2
Temperature (°C)	-29	38	93	149	204	260	316	343	371	399	425

PRESSURE / TEMPERATURE GRAPH :

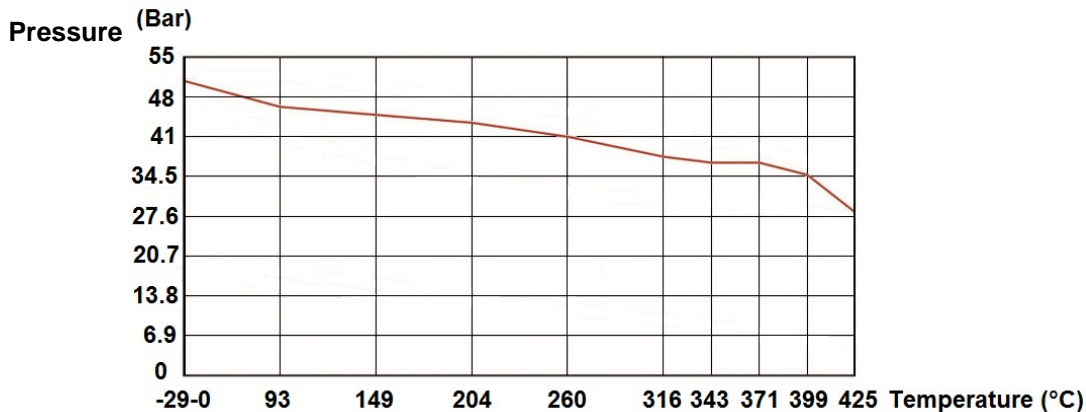

RANGE :

- Carbon steel gate valve with flanges R.F. Class 300 (PN50) **Ref. 144** From DN 50 to DN 350 (from NPS 2" to 14")
- Carbon steel gate valve with flanges R.F. Class 300 (PN50) with gearbox **Ref. 144** DN 400 (NPS 16")

CARBON STEEL GATE VALVE FLANGED CLASS 300 PN50

MATERIALS DN50-350 (NPS 2" to 14") :

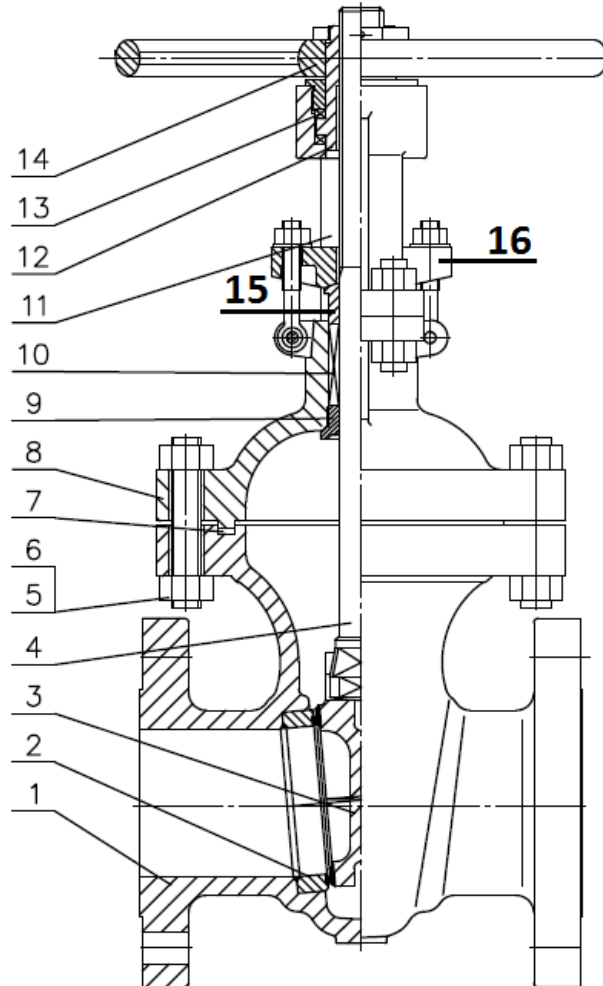

(* : included in gaskets kit)

Item	Designation	Materials
1	Body	ASTM A216 WCB
2	Seat	ASTM A105 + Stellite Gr.6
3	Wedge	ASTM A216 WCB + 13Cr
4	Stem	ASTM A182 F6a
5	Stud bolt	ASTM A193 Gr B7
6	Nut	ASTM A194 Gr 2H
7*	Bonnet gasket	SS 304 + graphite
8	Bonnet	ASTM A216 WCB
9	Back seat bushing	ASTM A276-420
10*	Packing	Flexible graphite
11	Yoke	ASTM A216 WCB
12	Stem nut	Aluminium + Bronze
13	Ring	E51100
14	Handwheel	Cast iron
15	Packing gland	ASTM A276-420
16	Gland flange	ASTM A216 WCB

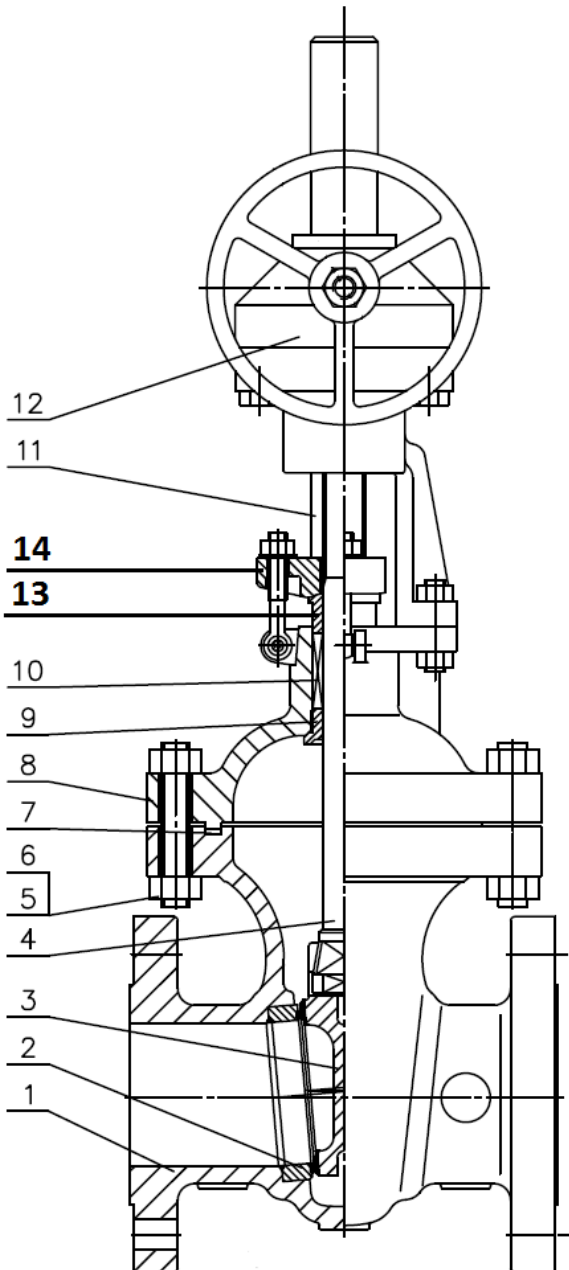
CARBON STEEL GATE VALVE FLANGED CLASS 300 PN50
MATERIALS DN400 (NPS 16") :

Item	Designation	Materials
1	Body	ASTM A216 WCB
2	Seat	ASTM A105 + Stellite Gr.6
3	Wedge	ASTM A216 WCB + 13Cr
4	Stem	ASTM A182 F6a
5	Stud Bolt	ASTM A193 Gr B7
6	Nut	ASTM A194 Gr 2H
7*	Bonnet gasket	SS 304 + graphite
8	Bonnet	ASTM A216 WCB
9	Back seat bushing	ASTM A276-420
10*	Packing	Flexible graphite
11	Yoke	ASTM A216 WCB
12	Gearbox	-
13	Packing gland	ASTM A276-420
14	Gland flange	ASTM A216 WCB

(* : included in gaskets kit)

CARBON STEEL GATE VALVE FLANGED CLASS 300 PN50

SIZE DN50-350 (NPS 2" to 14") (in mm):

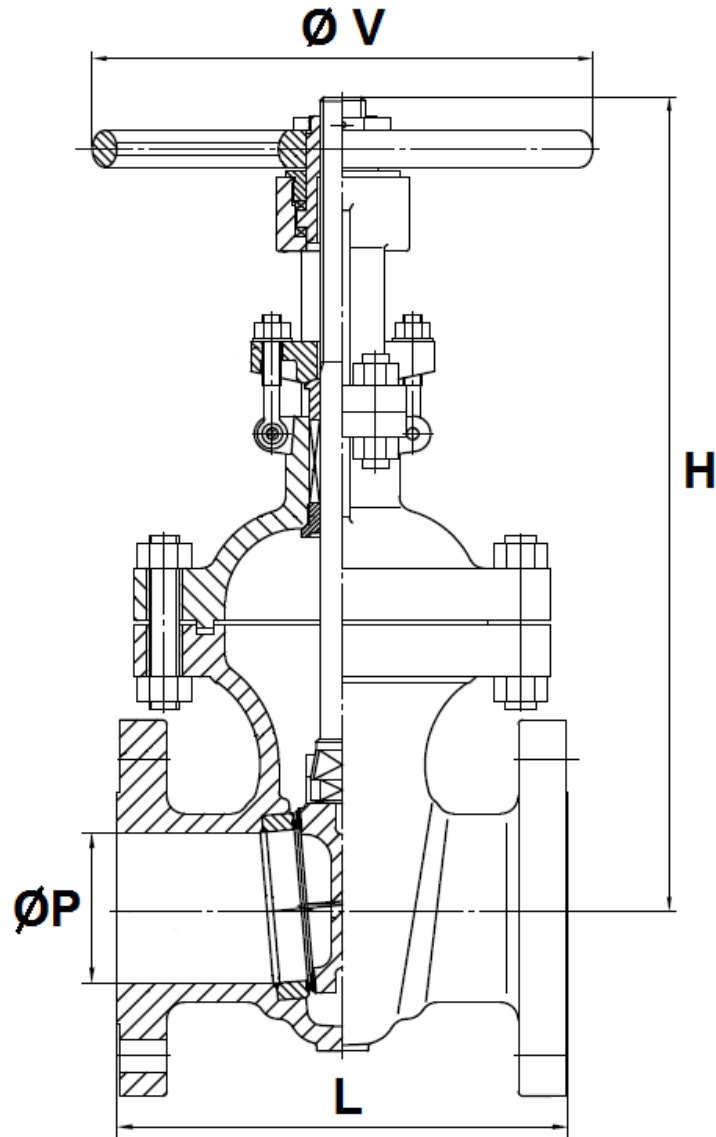

Ref.	DN (mm)	50	80	100	150	200	250	300	350
	NPS (")	2"	3"	4"	6"	8"	10"	12"	14"
144	Ø P	51	76	102	152	203	254	305	334
	L	216	283	305	403	419	457	502	762
	H (opened)	304	521	606	795	987	1228	1418	1574
	H (closed)	254	445	504	643	784	974	1113	1214
	Ø V	240	280	300	400	400	500	500	600
	Weight (Kg)	23	48	72	130	195	308	430	144

CARBON STEEL GATE VALVE FLANGED CLASS 300 PN50

SIZE DN 400 (NPS 16") (in mm) :

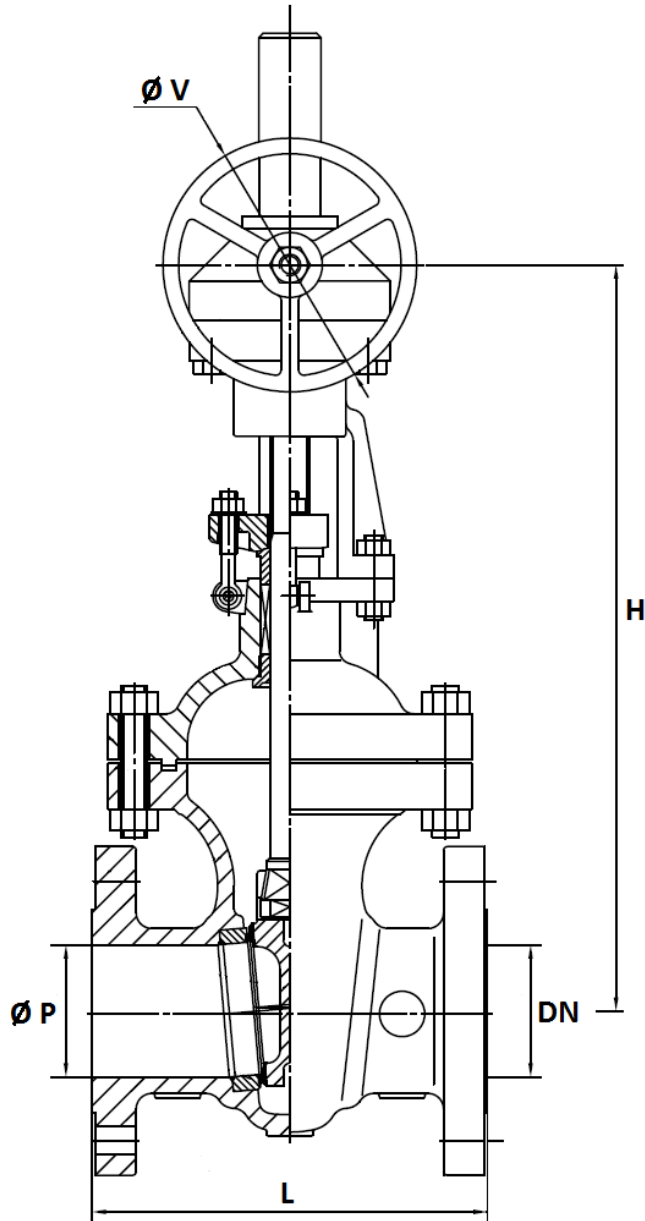

Ref.	DN (mm)	400
	NPS (")	16"
144	Ø P	385
	L	838
	H	1455
	Ø V	530
	Weight (in Kg)	805

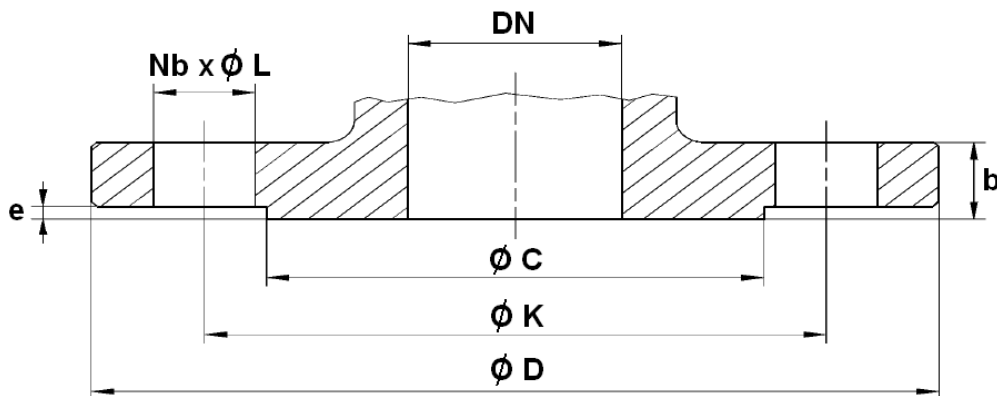
CARBON STEEL GATE VALVE FLANGED CLASS 300 PN50
FLANGES SIZE (in mm):

DN (mm)	50	80	100	150	200	250	300	350	400
NPS (")	2"	3"	4"	6"	8"	10"	12"	14"	16"
Ø C	92.1	127	157.2	215.9	269.9	323.8	381	412.8	469.9
Ø D	165	210	255	320	380	445	520	585	650
Ø K	127	168.3	200	269.9	330.2	387.4	450.8	514.4	571.5
Nb x Ø L	8 x 19	8 x 22	8 x 22	12 x 22	12 x 26	16 x 29	16 x 32	20 x 32	20 x 35
b	22.7	29	32.2	37	41.7	48.1	51.3	54.4	57.6
e	2	2	2	2	2	2	2	2	2

CARBON STEEL GATE VALVE FLANGED CLASS 300 PN50
TORQUE VALUE (in Nm without safety coefficient) :

DN	50	80	100	150	200	250	300	350	400
NPS (")	2"	3"	4"	6"	8"	10"	12"	14"	16"
Torque (Nm)	50	140	185	290	480	680	1000	1235	1665

NUMBER OF CYCLES TO CLOSE OR OPEN THE VALVE :

DN	50	80	100	150	200	250	300	350	400
NPS (")	2"	3"	4"	6"	8"	10"	12"	14"	16"
Number of cycles	15	29	23	28	36	45	54	46	52

STANDARDS :

- Fabrication according to ISO 9001 : 2008
- DIRECTIVE 97/23/CE : CE N° 0036
Risk category III H
- Designing according to API 600
- Pressure Tests according to API 598, table 6
- Length according to ASME B16.10, table 2 A10 series
- Flanges R.F. according to ASME B16.05
- ATEX Group II Category 2 G/2D Zone 1 & 21 Zone 2 & 22 (optional marking)
- Approval certificate Russian **GOST-R**
- Materials according to NACE MR 01-75 **on request**

ADVICE : Our opinion and our advice are not guaranteed and SFERACO shall not be liable for the consequences of damages. The customer must check the right choice of the products with the real service conditions.

CARBON STEEL GATE VALVE FLANGED CLASS 300 PN50**INSTALLATION INSTRUCTIONS****GENERAL GUIDELINES :**

- Ensure that the valves to be used are appropriate for the conditions of the installation (type of fluid, pressure and temperature).
- Be sure to have enough valves to be able to isolate the sections of piping as well as the appropriate equipment for maintenance and repair.
- Ensure that the valves to be installed are of correct strength to be able to support the capacity of their usage.
- **Installation of all circuits should ensure that their function can be automatically tested on a regular basis (at least two times a year).**

INSTALLATION INSTRUCTIONS :

- **Before installing the valves, clean and remove any objects from the pipes** (in particular bits of sealing and metal) which could obstruct and block the valves.
- **Ensure that both connecting pipes either side of the valve (upstream and downstream) are aligned (if they're not, the valves may not work correctly).**
- **Make sure that the two sections of the pipe (upstream and downstream) match, the valve unit will not absorb any gaps. Any distortions in the pipes may affect the tightness of the connection, the working of the valve and can even cause a rupture.** To be sure, place the kit in position to ensure the assembling will work.
- **If sections of piping do not have their final support in place, they should be temporarily fixed. This is to avoid unnecessary strain on the valve.**
- Tighten the bolts in cross.
- It's recommended to operate the valve (open and close) 1 to 2 times per year
- The valve should work in total opening or closing position (no intermediate positions), the valve must not be used for setting.
- Keep greased the stem so that the valve remains easy to open or close.